

90° T-pieces, 2 and 3 mm

Diameter for 2 mm: $\varnothing 80 - \varnothing 1000$ mm.

Diameter for 3 mm: $\varnothing 150 - \varnothing 1000$ mm.

90° T-pieces are welded and made of 2.00 and 3.00 mm sheet metal (s). T-pieces with $A = C \leq 400$ mm are supplied for assembly with pull rings [f.b]. T-pieces with $A = C \geq 450$ mm are supplied with flanges [m.fl].

For dimensions: $A = C \geq B$.

State A, B and C dimensions when ordering.

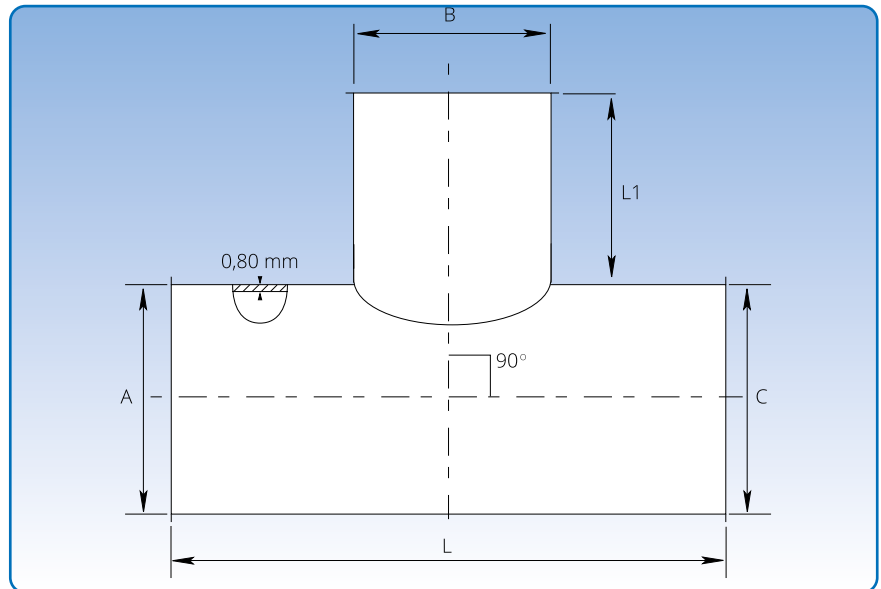

Dimensional specifications are given in the table below.

Dimensions			
B mm	s mm	L mm	L1 mm
80	2,00	230	75
100	2,00	250	75
120	2,00	270	75
125	2,00	275	75
140	2,00	290	75
150	2,00 and 3,00	300	75
160	2,00 and 3,00	310	75
180	2,00 and 3,00	330	75
200	2,00 and 3,00	350	75
225	2,00 and 3,00	425	100
250	2,00 and 3,00	450	100
275	2,00 and 3,00	475	100
300	2,00 and 3,00	500	100
315	2,00 and 3,00	515	100
350	2,00 and 3,00	550	100
400	2,00 and 3,00	600	100
450	2,00 and 3,00	750	150
500	2,00 and 3,00	800	150
550	2,00 and 3,00	850	150
600	2,00 and 3,00	900	150
630	2,00 and 3,00	930	150
650	2,00 and 3,00	950	150
700	2,00 and 3,00	1100	200
750	2,00 and 3,00	1150	200
800	2,00 and 3,00	1200	200
850	2,00 and 3,00	1250	200
900	2,00 and 3,00	1300	200
950	2,00 and 3,00	1350	200
1000	2,00 and 3,00	1400	200